



2. Getting Started
4. Holder Installation and Setup
6. Administrative Functions
7. Setting Up a Rabies Tag
11. Engraving a Rabies Tag
16. Engraving a Custom Tag
24. Engraving Clipart
25. International Characters
27. Clipart
29. Troubleshooting

Look for tips and tricks
on the inside back cover.

IMPORTANT NOTE:

The iMARC is equipped to engrave only on iMARC manufactured tags and plates with iMARC manufactured tag holders. Use of tags or tag holders not manufactured by iMARC, or any modifications to iMARC tag holders or machine will void your warranty, and may cause serious damage to your iMARC Engraver.

GETTING STARTED



Before you plug in your new iMARC and engrave your first tag, familiarize yourself with some of the components of the machine.

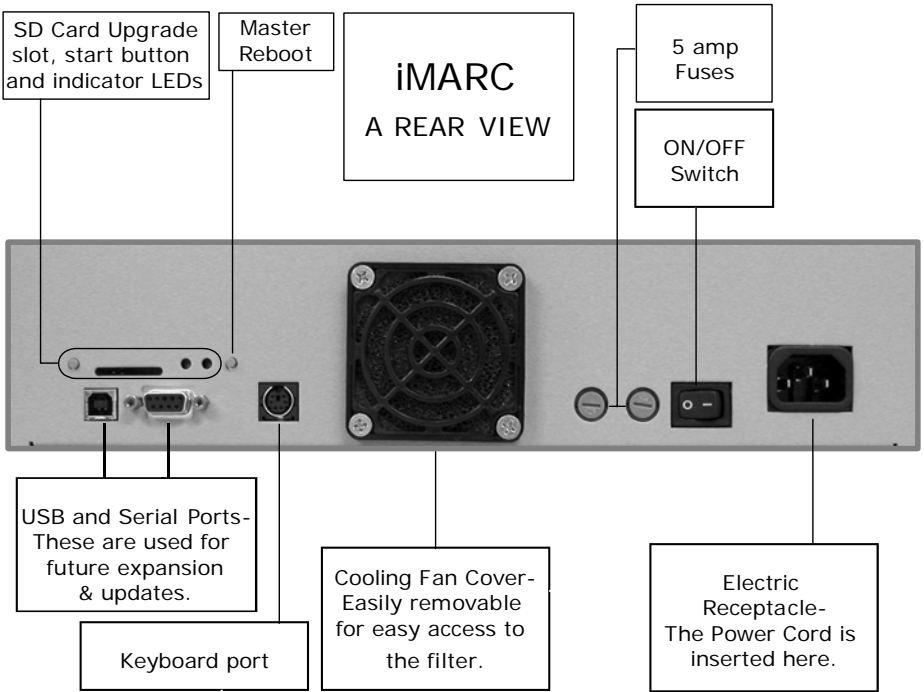



GETTING STARTED

Setting up your iMARC is quick and easy.



Plug in the keyboard into the keyboard port.



Plug your power cord into the electric receptacle.



Plug the cord into any standard (110 Volt) outlet,
and switch on the machine.

Note: If your machine is configured for 220 volts, there will a label (shown below) on the back side of your machine, near the electric receptacle.

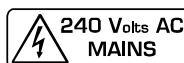

HOLDER INSTALL & SETUP



Once you've turned on your iMARC system, it is now time to install the holders. Your holders need to be installed on the engraving table during HOLDER SETUP.

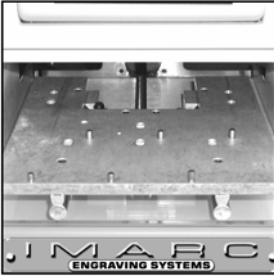

*Engraving Table-
No holders installed*



Tag Holder



*Engraving Table-
With holders installed*

Select the holders that you want to install – iMARC can accommodate 3 holders at one time. If you've purchased more than 3, refer back to this page when you want to change holders.

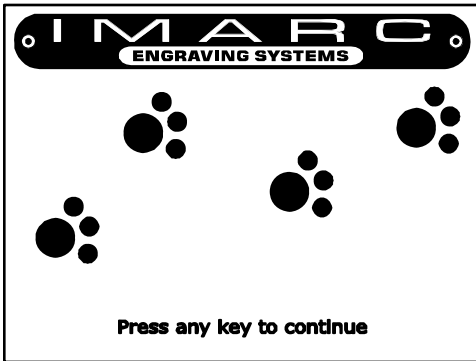

This is the first screen you will see. This is the INTRODUCTION SCREEN.

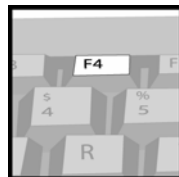

From the INTRODUCTION SCREEN, press F4 for holder setup.

Note: Holders can only be installed when you are in the HOLDER SETUP screen. Attempting to install them at any other time could result in damage to the holders or the machine. Also, do not try to place a tag into the holder during holder setup, as this too can result in damage.



HOLDER INSTALL & SETUP

The holder setup is simple. You can follow the on screen instructions as well as the steps on this page.

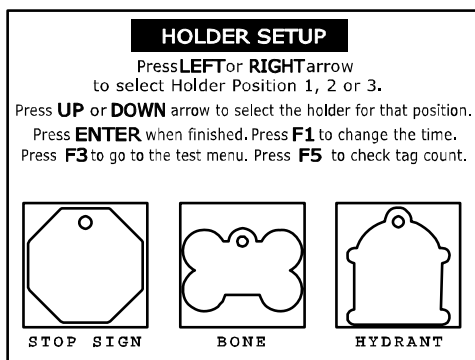

This is the HOLDER SETUP screen. The current position to be installed will be flashing.

Insert your first holder into position 1 on the engraving table.

Note: For easiest installation and removal, position the holes in the holder directly over the pins in the engraving table, and move the holders directly up and down over the pins. It may be a snug fit, so apply light pressure as needed.

Step 1

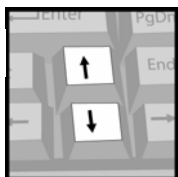

In position 1, press the up and down arrow keys to scroll to the holder you've installed.

Step 2



Press the right arrow key to toggle to position 2. Do the same for position 3.

Follow these instructions for all three positions, installing a holder into each position as you go. If you want to use only one holder, be sure to install it in the center position.

Step 3

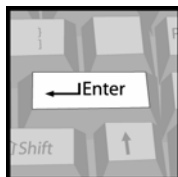

Press Enter to save your changes.

Note: If using the Stall, Halter, or Saddle plates, you must set it up in the center position.

For instructions on setting the time, using the test menu, or checking your tag count, please turn to the next page.

ADMINISTRATIVE FUNCTIONS



All of the functions that you and your managers might require can be found by accessing the holder setup screen. (F4 from the introduction screen)

HOLDER SETUP
Press **LEFT** or **RIGHT** arrow to select Holder Position 1, 2 or 3.
Press **UP** or **DOWN** arrow to select the holder for that position.
Press **ENTER** when finished. Press **F1** to change the time.
Press **F3** to go to the test menu. Press **F5** to check tag count.

STOP SIGN BONE HYDRANT

Press F1 to enter the correct local time and date. This is important to do before starting to serialize your rabies tags.

TIME EDIT
Use the **TAB** key to change between time and date.
Press **ENTER** to save and exit.
Press **ESC** to exit without saving.
Press **F4** to reset clock and RAM.
Time is 24 hour clock in HH:MM:SS.
Date is in MM/DD/YY format.
TIME:
DATE:

The iMARC contains an internal clock that will keep time even if it is unplugged.

All tests are done during assembly. However, we've provided access just in case. Press F3 to run tests.

TEST MENU
Please select the test you wish to do.

- F1: Move test.
- F2: Center point test.
- F3: Leadscrew test.
- ESC: Return to start screen.

Utilize the tag count screen to monitor your tag sales and track inventory.

TAG COUNT SCREEN
Your current tag output count is
000004
To go back press **ESC**



SETTING UP A RABIES TAG

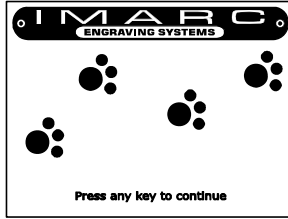

At the INTRODUCTION SCREEN,
Press any key

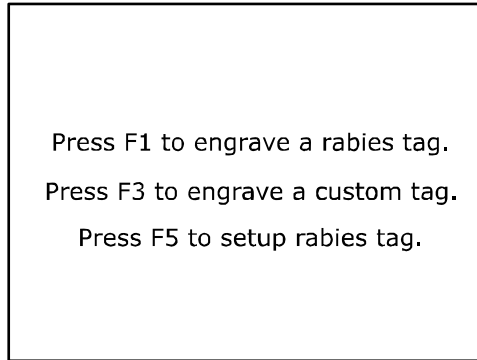

Very few steps are required to set up your Rabies tag serialization function. Once you've finished with this section, you will be able to engrave all of your clinic's information with just a few steps.

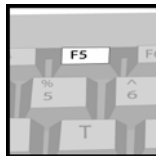

In the Function Screen (shown above) press F5 to setup your Rabies tag number, date and clinic information.

SETTING UP A RABIES TAG



TAG SELECTION

Press **UP** or **DOWN** arrow to select the tag you want to engrave.

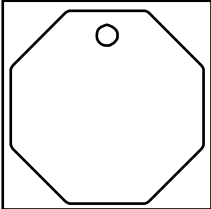

**LARGE STOP SIGN
LEFT HLDR**

Press **F4** for holder setup.
To Continue press **ENTER** To go back press **ESC**

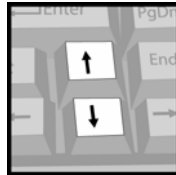

In the TAG SELECTION screen, move through the available tags using the up and down arrow keys.

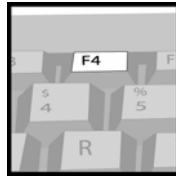

If the tag you want to engrave does not show up on the screen, press F4 to return to HOLDER SETUP and install the correct holder. (See pg. 5 for instructions.)

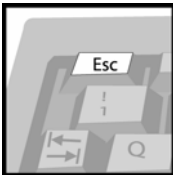

Press Escape to quit...

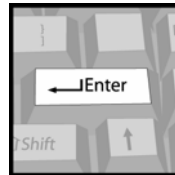

Press Enter to Continue...



SETTING UP A RABIES TAG

RABIES TAG SETUP

ESC Exit Program F8 Edit Rabies Number
F2 Save Data F10 Insert Date
F4 Clear Tag F12 Insert Rabies Number
F6 Help Screen

LG CIR/ROSETTE

Line 1: VISION VET
Line 2: 17621 BLACK CANYON
Line 3: PHOENIX AZ 85023
Line 4: 602-439-0600
Line 5: ■-DATE-■
Line 6: ■-RN-■

In the Rabies Tag Setup screen, type in the information you would like on each line, and press enter to move to the next line. Follow the instructions below to insert your sequence number and date.

Attention: Each tag size may have its own restrictions regarding amount of lines and characters. Please refer to the template pages before continuing.

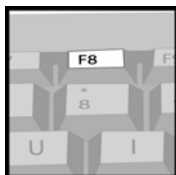

Press F8 to set up your rabies sequence. (See next page.)

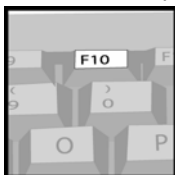

With the cursor in the desired line, press F10 to insert the date.

You will only see

■-DATE-■

displayed on the line that will engrave the date.

Note: If you haven't set up the correct date, see page 6.

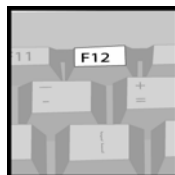

With the cursor in the desired line, press F12 to insert your rabies sequence number.

You will only see

■-RN-■

displayed on the line that will engrave the rabies number.

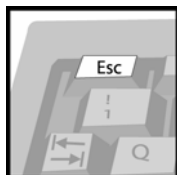

Press ESC at any time to go back to TAG SELECTION.



Press F2 to save and continue. The CHECK TEXT screen will appear. Confirm that the text is correct and press enter to continue. Then proceed to page 11.

SETTING UP A RABIES TAG

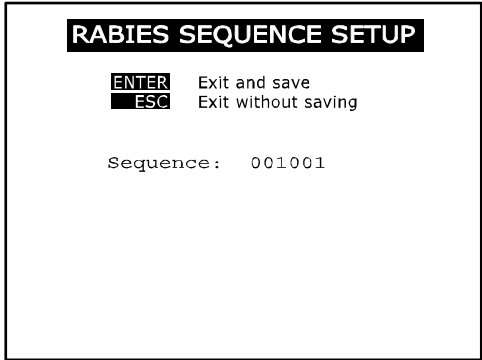

In the RABIES SEQUENCE SETUP screen, simply enter the sequence number that you want to start with.
Note: The iMARC will automatically sequence your rabies tags as you make them.

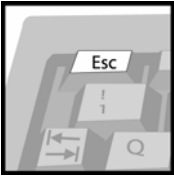

Press ESC at any time to go back to the setup screen without saving.



Press Enter to save and continue with setup.
(Return to previous page)



ENGRAVING A RABIES TAG

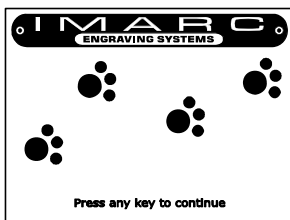

At the INTRODUCTION SCREEN,
Press any key

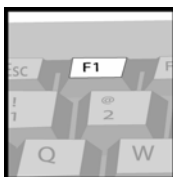
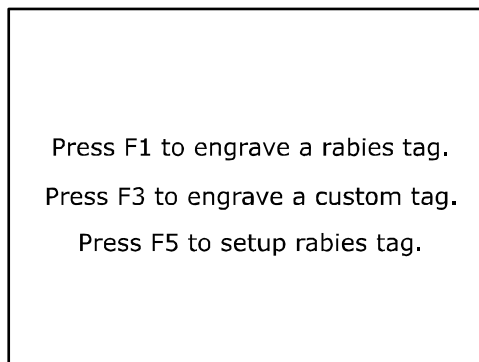

In the Function Screen (shown above), press F1.
To setup your Rabies tag dating, serialization and
clinic information press F5 and turn to page 8.

*Note: You can only engrave a rabies tag using the standard
type style (iMARC Block). To engrave a custom tag using
another type style, press F3 and turn to page 16.*

ENGRAVING A RABIES TAG



TAG SELECTION

Press **UP** or **DOWN** arrow to select the tag you want to engrave.

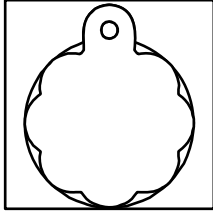

LG CIR/ROSETTE
RIGHT HLDR

Press **F4** for holder setup.
To Continue press **ENTER** To go back press **ESC**

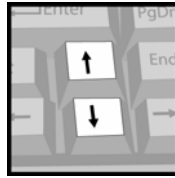

In the TAG SELECTION screen, select the Rabies tag shape chosen during rabies tag setup. Should you choose a tag other than that one, the screen below will appear. Press F1 and turn to page 8 to set up that tag.

THERE IS NO PRE-SET DATA IN THIS TAG

Press F1 to setup rabies tag.

Press F3 to select a new tag.

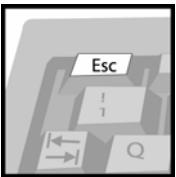

Press Escape to quit...

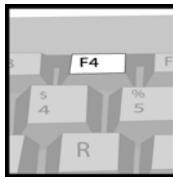

If the tag you want to engrave does not show up on the screen, press F4 to return to HOLDER SETUP and install the correct holder. (See page 5.)

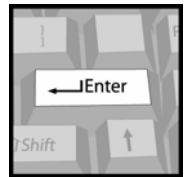

Press Enter to Continue...



ENGRAVING A RABIES TAG

CHECK TEXT

Please ensure the text you have entered is correct.

VISION VET
17621 BLACK CANYON
PHOENIX AZ 85023
602-439-0600
■-DATE-■
■-RN-■

Font to be engraved is **iMARC Block**

To engrave deeper press **2**. Press **F4** for holder setup.
To Continue press **ENTER** To go back press **ESC**

In the Rabies tag CHECK TEXT screen, confirm that the information entered is correct, and that the date is current.

Note: Text will not be enlarged to fit on the screen, but will be expanded or condensed to fit on the finished tag.

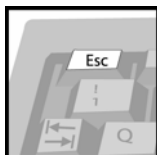

Press Esc
to go back.

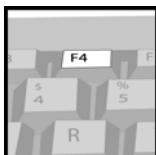

Press F4 to
change your
tag holder.

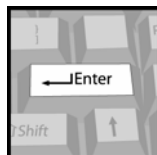

Press Enter
to continue.

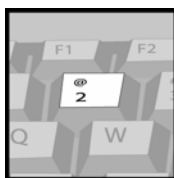

Pressing the number 2 will automatically engrave your tag twice, making the final engraving deeper.

ENGRAVING A RABIES TAG



PET TAG
IS NOW ENGRAVING!

Press ESC to cancel

PLEASE WAIT

The table will be pulled back into the iMARC and the door will close. While your tag is engraving, you will see the screen shown above.

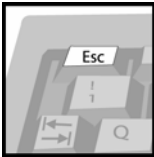

Press Esc at any time to stop the engraving process.

Note: Pressing ESC before iMARC starts to engrave will stop the machine before it engraves into the tag.



ENGRAVING A RABIES TAG

CONGRATULATIONS!

You have successfully engraved your tag!
Please remove your tag.

Press **F1** to engrave the back of this tag

Press **F2** to engrave a new tag

To reengrave last tag, press **R**.

To engrave next rabies tag, press **1**.

To engrave next rabies tag two times, press **2**.

To edit text press **F8**.

Press **F4** for holder setup.

Press **ESC** to return to the start screen.

When your tag is finished, the table will move out. When it stops, you can remove your tag, or flip it over to engrave the other side.



Once your tag is completed, press **F1** to engrave the other side of your tag.

Note: This will bring you back to the CHOOSE FONT screen.



Press **F2** to start a new tag.

Note: This will bring you back to the TAG SELECTION screen.



To repeat the same engraving on a new tag, press the number 1.

Note: The iMARC will automatically begin the engraving process.



Pressing the number 2 will repeat your last engraving, and will automatically engrave the tag twice, making the final engraving deeper.



Press **Esc** to return to the INTRODUCTION SCREEN.

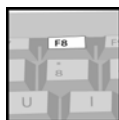

Press **F8** to edit your text.
Note: This will bring you back to the TEXT ENTRY screen.



Press **F4** to change your tag holder.

ENGRAVING A CUSTOM TAG

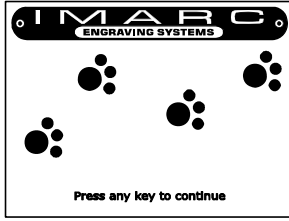

From the INTRODUCTION SCREEN, press any key to get started.

Note: After a period without keystrokes, the machine will reset to this screen.

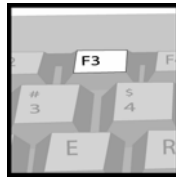
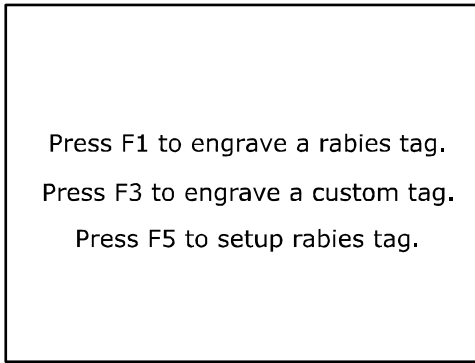

Engraving your tag is quick and easy. Each option is clearly stated as you follow the steps to your completed tag.

In the Function Screen, press F3.



ENGRAVING A CUSTOM TAG

TAG SELECTION

Press **UP** or **DOWN** arrow
to select the tag you want to engrave.

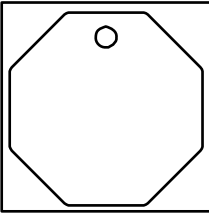

**LARGE STOP SIGN
LEFT HLDR**

Press **F4** for holder setup.
To Continue press **ENTER** To go back press **ESC**

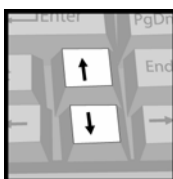

In the TAG SELECTION screen, move through the available tags using the up and down arrow keys.

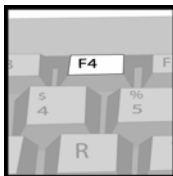

If the tag you want to engrave does not show up on the screen, press F4 to return to HOLDER SETUP and install the correct holder. (See pg. 5 for instructions.)

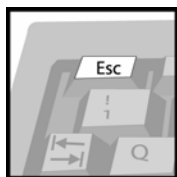

Press Escape to quit...

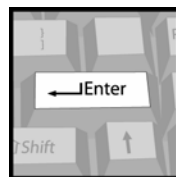

Press Enter to Continue...

ENGRAVING A CUSTOM TAG



After you've selected your tag,
choose your type style.

CHOOSE FONT
Select font to continue.

1. 1L Block	5. CONTEMPORARY
2. 2L Century	6. 3L ROMAN
3. 2L BLOCK	7. 5L Optima
4. Script	8. Clipart
	9. Your Logo (optional)

To go back press **ESC**

From the CHOOSE FONT screen, select the desired type style by simply pressing the corresponding number on the keyboard.

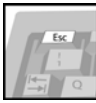
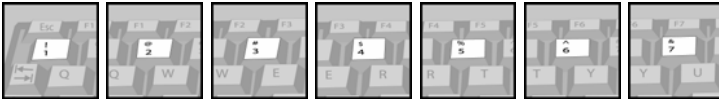

Hint: Pressing ENTER will select the iMARC BLOCK type style.

Press Esc to return to the TAG SELECTION screen.

OPTIONAL LOGO FUNCTION-



8 FOR CLIPART

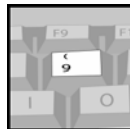

9 FOR YOUR LOGO

To engrave clipart onto your iMARC tags, press 8 and turn to page 24 for additional instructions.

If your iMARC has your company's logo stored in it, press 9 to select your logo and enter the letter A to engrave it.



ENGRAVING A CUSTOM TAG

Once you've selected a type style, it is time to type in the information to be engraved.

Type information to be engraved.

ESC CHANGE FONT

F2 ENGRAVE TAG

F8 CLEAR TEXT

F6 HELP SCREEN

F4 HOLDER SETUP

09:15:30
08/28/04

LARGE STOP SIGN **LEFT HLDER**

Note: Caps Lock is on if CAPS shows in the top left of the iMARC screen.

Type in your information as you would like it to appear on the front of the tag. Keep in mind that iMARC will automatically increase or decrease your type size for optimum coverage. Press Enter once to go to the next line, twice to skip a line, or backspace to edit.

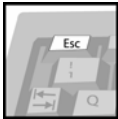

Press Esc to change your type style.



Press F6 to go to the help screen.

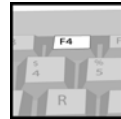

Press F4 to change your tag holder.

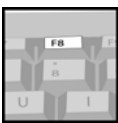

Press F8 to clear your information and start again.

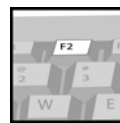

Press F2 to insert your tag into the holder.

ENGRAVING A CUSTOM TAG



ENGRAVE TAG

You are about to engrave a
STOP SIGN tag in **LEFT HLD**
Ensure the correct tag is loaded in the correct holder.
Press **F4** for holder setup.

To Continue press **ENTER** To go back press **ESC**

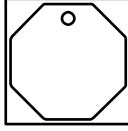

STOP SIGN

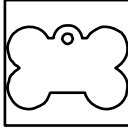

BONE

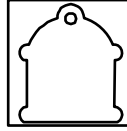

HYDRANT

The door will open and the table will move out for tag insertion. The tag position will flash indicating where to insert the tag to be engraved.

Note: Ensure that your tag is inserted completely flat into the tag holder.

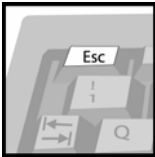

Press Esc at any time to go back to the TEXT ENTRY screen.

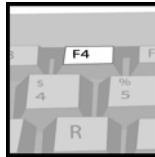

Press F4 to change your tag holder.

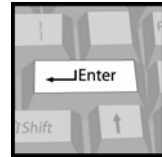

Press Enter to confirm your tag choice and placement, and proceed to the CHECK TEXT screen.



ENGRAVING A CUSTOM TAG

CHECK TEXT

Please ensure the text you have entered is correct.

Joe Black
1345 E. Flint St
Phoenix, Az

Font to be engraved is **Script**

To engrave deeper press 2. Press **F4** for holder setup.
To Continue press **ENTER** To go back press **ESC**

Using the CHECK TEXT screen, make sure you've typed in your information correctly and that you have chosen the correct type style.

Note: Text will not be enlarged to fit on the screen, but will be at the proper size on the tag.

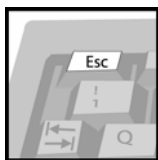

Press Esc at any time to go back to the text entry screen.

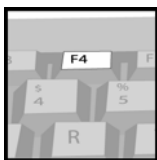

Press F4 to change your tag holder.

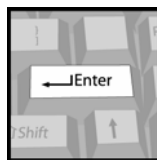

Press Enter to engrave your tag.

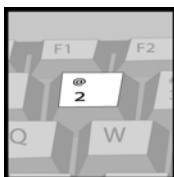

Pressing the number 2 will automatically engrave your tag twice, making the final engraving deeper.



PET TAG
IS NOW ENGRAVING!

Press ESC to cancel

PLEASE WAIT

The table will be pulled back into the iMARC and the door will close. While your tag is engraving, you will see the screen shown above.

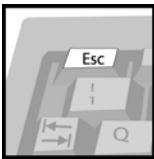

Press Esc at any time to stop the engraving process.

Note: Pressing ESC before iMARC starts to engrave will stop the machine before it engraves into the tag.



ENGRAVING A CUSTOM TAG

CONGRATULATIONS!

You have successfully engraved your tag!
Please remove your tag.

Press **F1** to engrave the back of this tag

Press **F2** to engrave a new tag

To repeat this tag - insert new tag & Press **1**

To engrave this tag two times, press **2**.

To edit text press **F8**.

Press **F4** for holder setup.

Press **ESC** to return to the start screen.

When your tag is finished, the table will move out. When it stops, you can remove your tag, or flip it over to engrave the other side.



Once your tag is completed, press F1 to engrave the other side of your tag.

Note: This will bring you back to the CHOOSE FONT screen.



Press F2 to start a new tag.

Note: This will bring you back to the TAG SELECTION screen.



To repeat the same engraving on a new tag, press the number 1.

Note: The iMARC will automatically begin the engraving process.



Pressing the number 2 will repeat your last engraving, and will automatically engrave the tag twice, making the final engraving deeper.



Press Esc to return to the INTRODUCTION SCREEN.

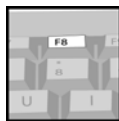

Press F8 to edit your text.
Note: This will bring you back to the TEXT ENTRY screen.



Press F4 to change your tag holder.

ENGRAVING CLIPART



CHOOSE FONT
Select font to continue.

1. 1L Block	5. CONTEMPORARY
2. 2L Century	6. 3L ROMAN
3. 2L BLOCK	7. 5L Optima
4. <i>Script</i>	
8. Clipart 	
9. Your Logo (optional)	

To go back press **ESC**

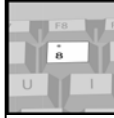

From the CHOOSE FONT screen, press the number 8.

Type information to be engraved.

A ■

ESC CHANGE FONT
F2 ENGRAVE TAG
F8 CLEAR TEXT
F6 HELP SCREEN
F4 HOLDER SETUP

04:25:3 0
06/6/0 6

LARGE STOP SIGN LEFT HLDER



From the available clipart shown on pages 27 and 28, type the character representing the clipart you've chosen into the INPUT SCREEN, and then press F2.

Note: The character you enter here represents the clipart you've chosen and will not be engraved.

CHECK TEXT
Please ensure the text you have entered is correct.

A

Font to be engraved is Your Clipart

To engrave deeper press 2. Press **F4** for holder setup.
To Continue press **ENTER** To go back press **ESC**

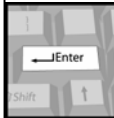

Press Enter to engrave the tag, or the number 2 for deeper engraving.

If you would like to add your company's logo to your iMARC, call 888-99-iMARC or email us at sales@imarcengraver.com



INTERNATIONAL CHARACTERS

The iMARC is capable of engraving international characters, however they are not available with every type style.

To utilize all of the special characters, you will need to use the *iMARC Block* type style.

Some characters may be available with other type styles.

Caps lock key OFF				
	Alt Key	Shift+Alt Key	Ctrl Key	Shift+Ctrl Key
A	à	Â	ä	Á
E	è	Ê	ë	É
I	ì	Î	ï	Í
O	ò	Ô	ö	Ó
U	ù	Û	ü	Ú
Y			ÿ	Ý
N			ñ	
C			ç	
1		ğ	ã	
2		ş	å	
3		ı	õ	
4			æ	
5				
6			ø	
7				
8				

Example: To get the letter è, you would need to have the caps locks key off, hold the alt key and press E.
 To get the letter Ñ, you would need to have the caps locks key on, hold the ctrl key and press N.
 To get the letter Æ, you would need to have the caps locks key on, hold the ctrl key and press 4.



Caps lock key ON				
	<i>Alt</i> Key	<i>Shift+Alt</i> Key	<i>Ctrl</i> Key	<i>Shift+Ctrl</i> Key
A	À	â	Ä	á
E	È	ê	Ë	é
I	Ì	î	Ï	í
O	Ò	ô	Ö	ó
U	Ù	û	Ü	ú
Y				ý
N			Ñ	
C			Ç	
1		Ğ	Ā	
2		Ş	Å	
3		İ	Ö	
4			Æ	
5			ß	
6			Ø	
7			ı	
8			ç	

Example: To get the letter è, you would need to have the caps locks key off, hold the alt key and press E.
 To get the letter Ñ, you would need to have the caps locks key on, hold the ctrl key and press N.
 To get the letter Æ, you would need to have the caps locks key on, hold the ctrl key and press 4.

Instructions: To use the various clipart available in your iMARC, select the image you want, proceed through the tag selection screens as normal. In the **CHOOSE FONT** screen, press #8 then simply type the corresponding number of your image in the **TEXT ENTRY** screen. Then press F2 and proceed as normal.

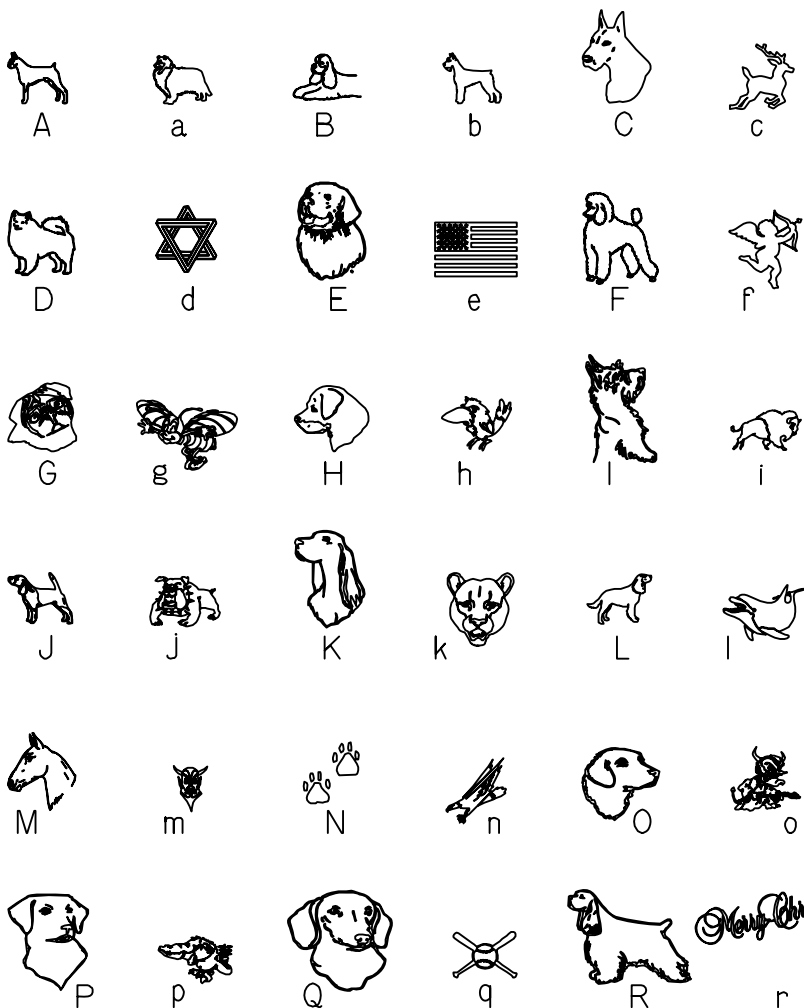

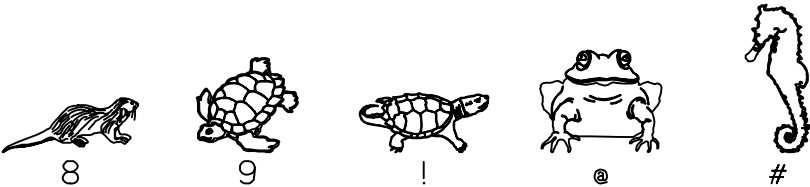
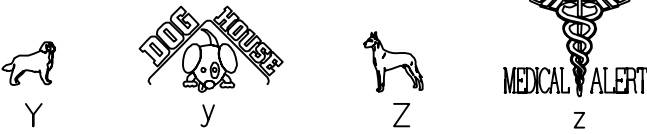
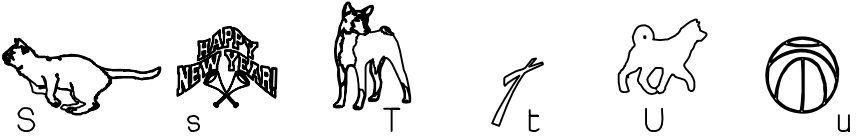



Adjusting the LCD contrast.



With your iMARC on, locate the LCD contrast wheel near the lower left front side of the machine. Using the tip of a pen (*Do NOT use a paper clip!*) apply *light* pressure to adjust the LCD contrast wheel inside the iMARC. Turn it left or right until the contrast is the way you like it.

Resetting the RAM

Use this procedure if a large or small shape is missing on the iMARC screen when trying to engrave a tag.

This will clear all holders, time and date.



From the INTRODUCTION SCREEN, press F4 to go to the HOLDER SETUP screen. Then press F1 to go to the time edit screen. While in the TIME EDIT screen, press F4 to reset the machine. The time will change to zero. Reset the time and date as needed and press ENTER.

Press F4 again to set up your holders. (*See page 5.*)